

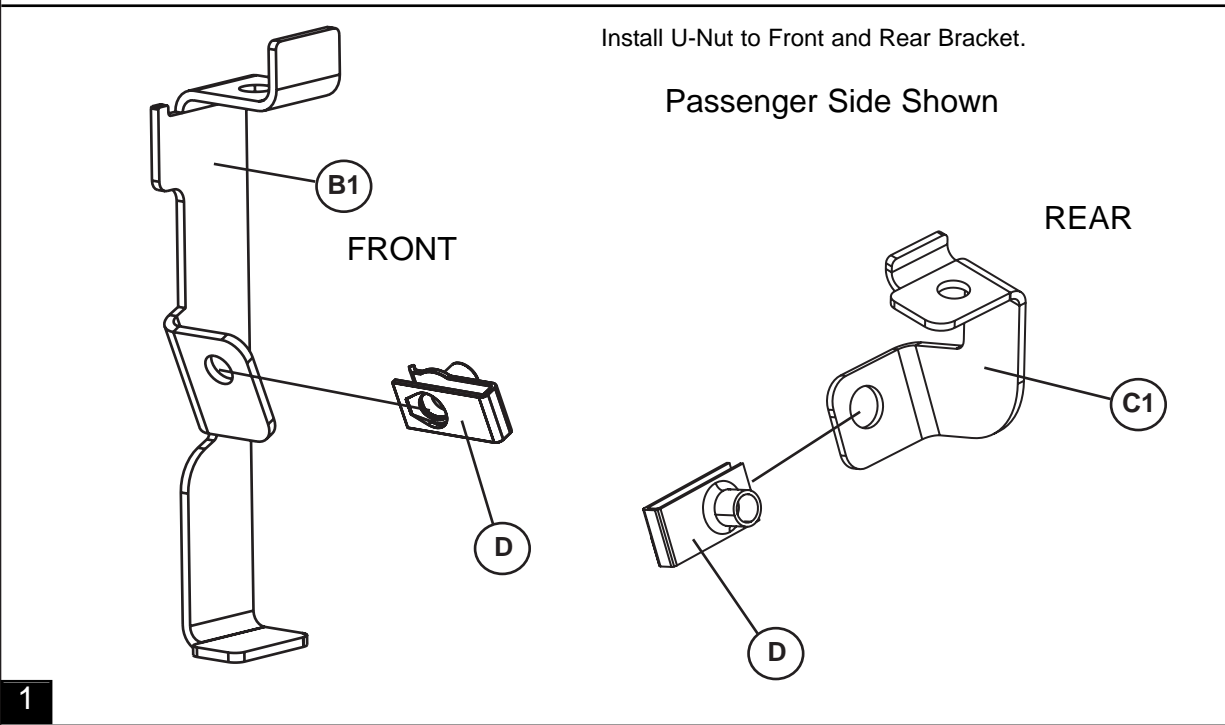

# Dodge Ram

Tubular Bed Rails

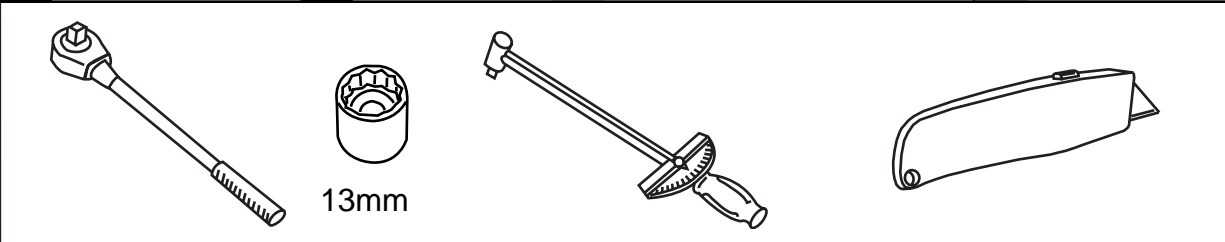

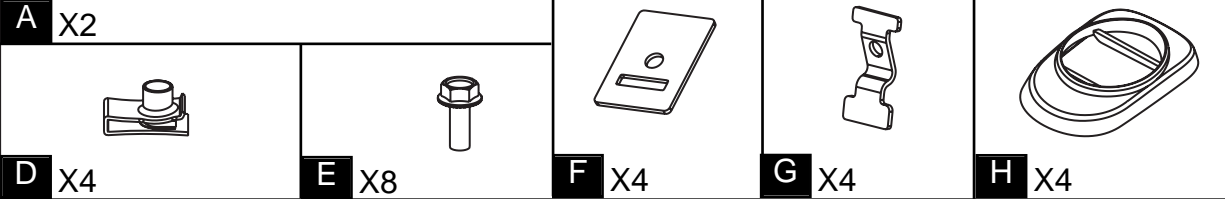
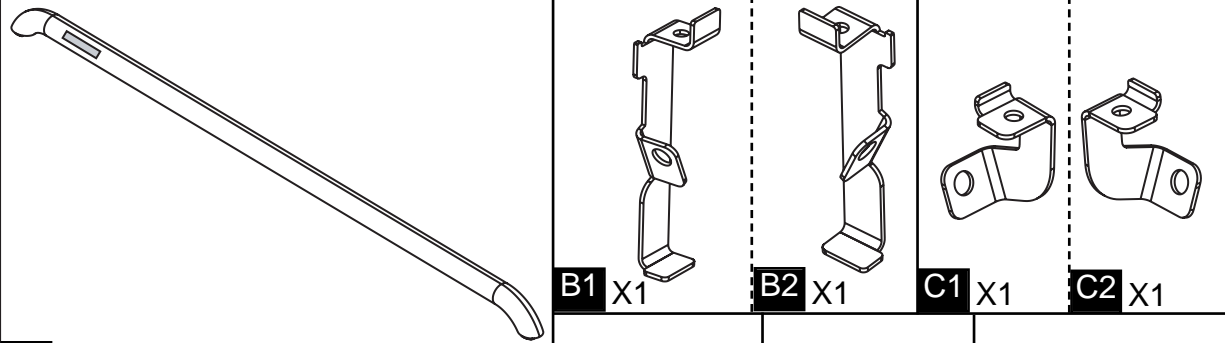

13mm



20 +7/-0 (N.m)  
15 +5/-0 ft-lb

Passenger Side  
Shown

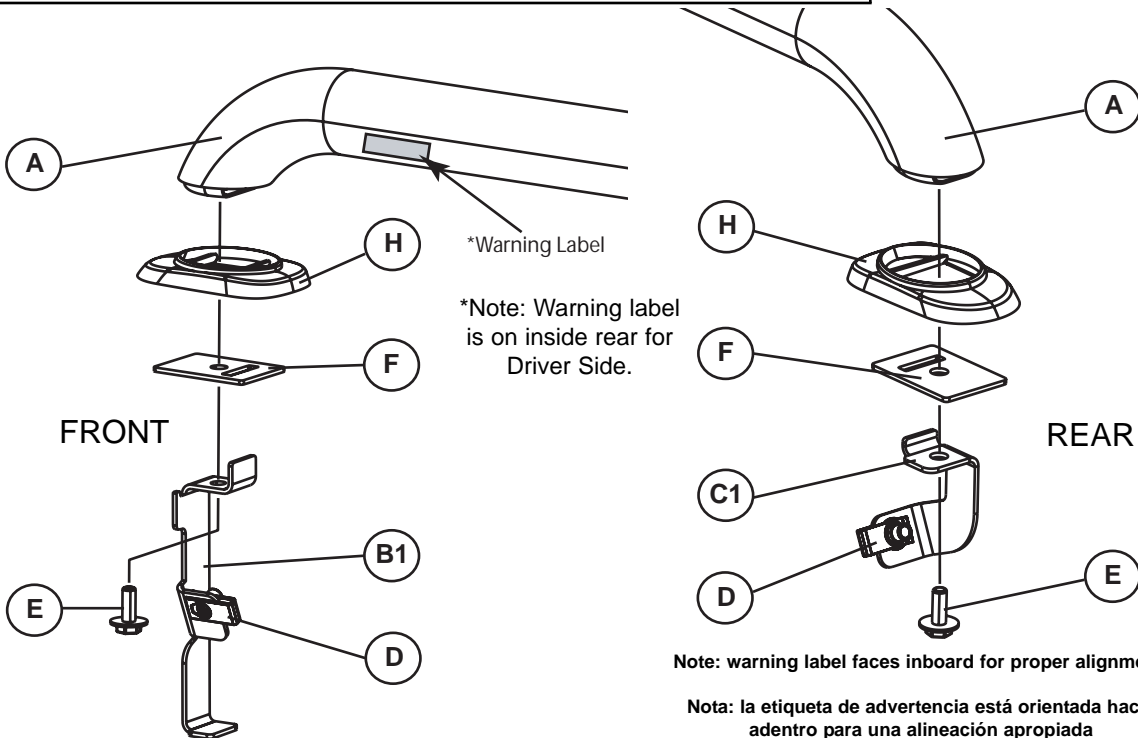

Note: warning label faces inboard for proper alignment.

Nota: la etiqueta de advertencia está orientada hacia adentro para una alineación apropiada

Remarque: L'étiquette d'avertissement s'oriente vers l'intérieur pour un bon alignement.

Assemble the Bracket, Clamping Plate and Bezels to Tube with M8 Bolt with ratchet.

**2** Torque to a minimum 20N.m (15 ft.lbs).

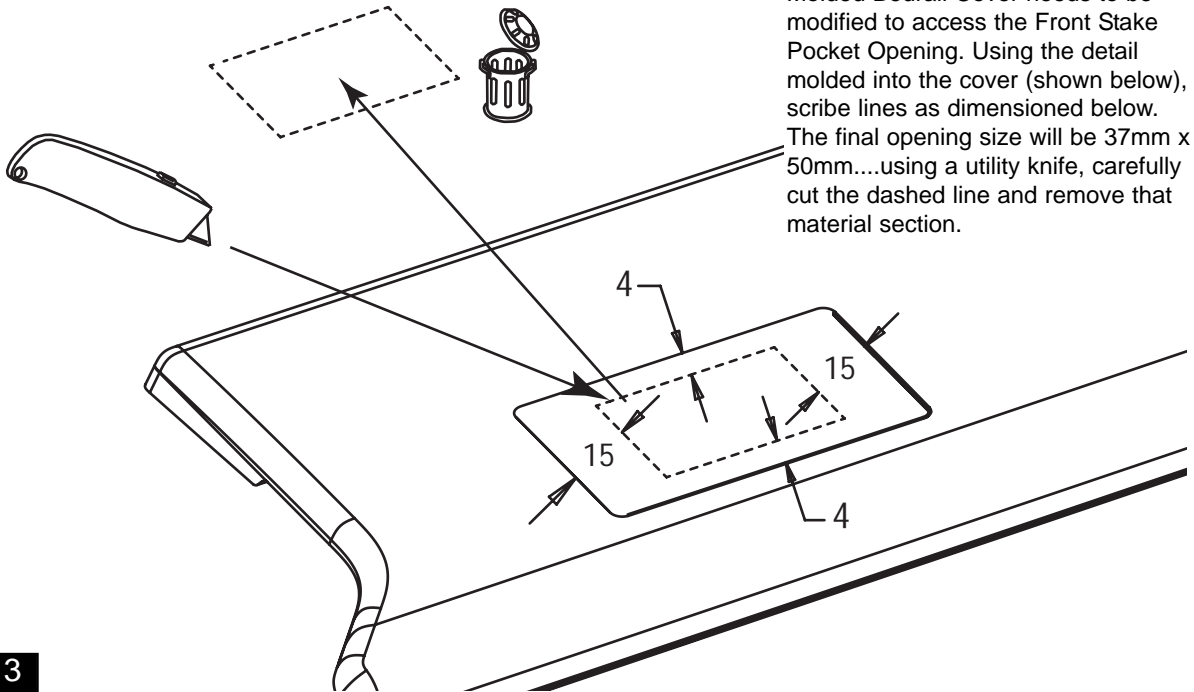

If truck has bedliner, it must be removed to do this installation.

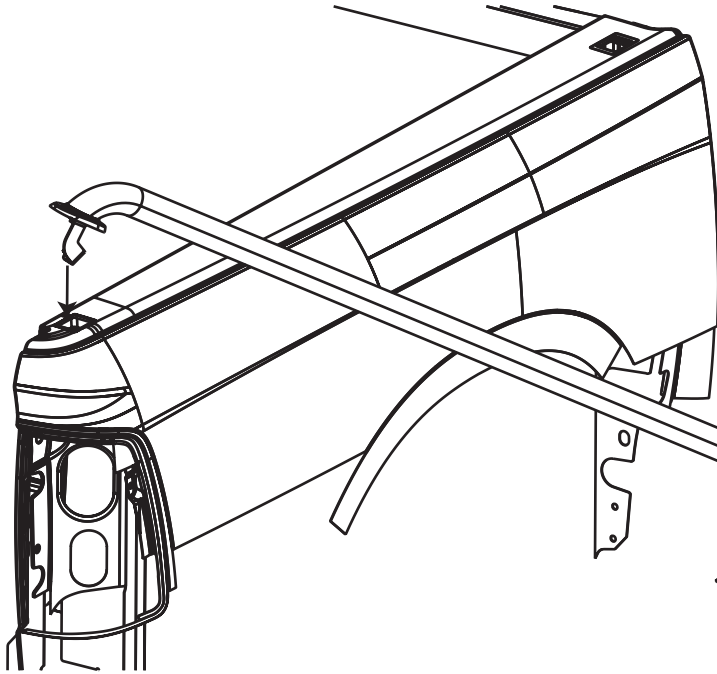

Remove Bedliner, installation is much easier to do so, rather than trying to modify the bedliner to install hardware. Put the rear bracket into truck box by tilting the assembly as shown.

4 Be careful not to scratch the truck paint.

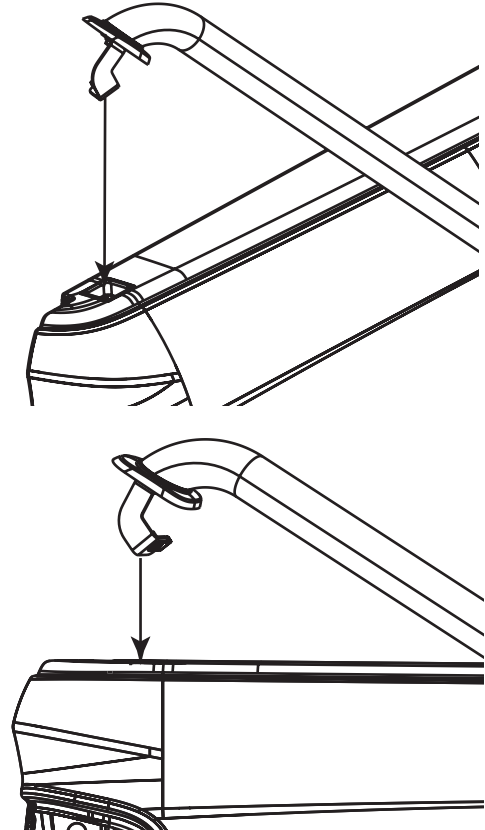

Lift the front side of the Tube higher than the truck box. **Caution - do not scratch vehicle when lifting.** Align and put the front bracket into the truck box.

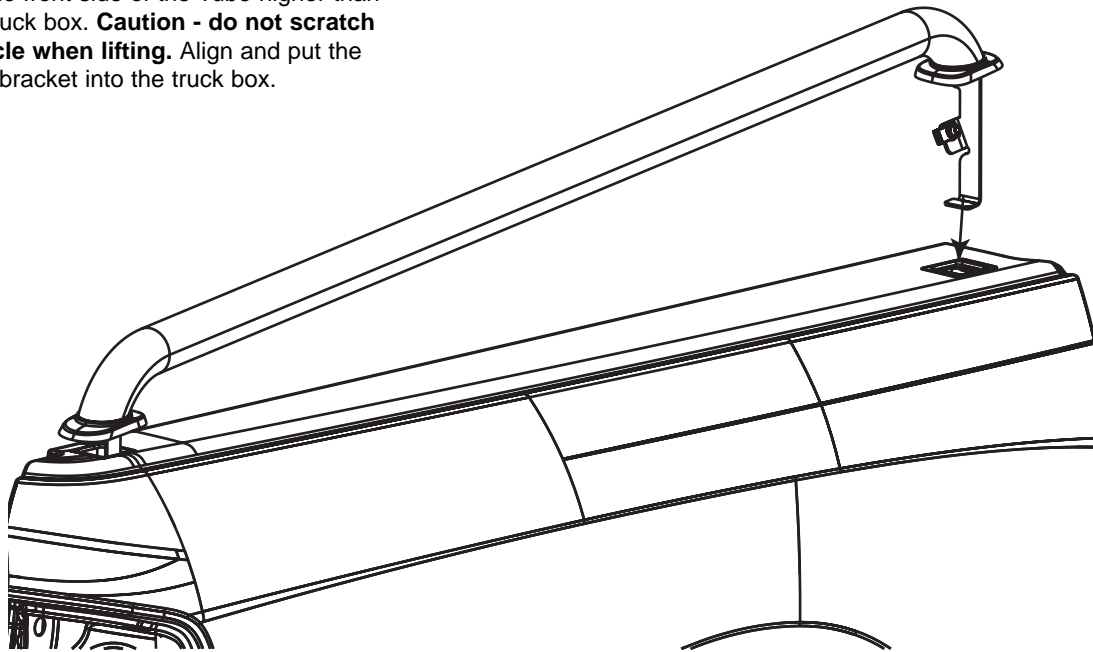

5

Passenger Side Shown

FRONT

REAR

\*Note: Warning label is on inside rear for Driver Side.

\*Warning Label

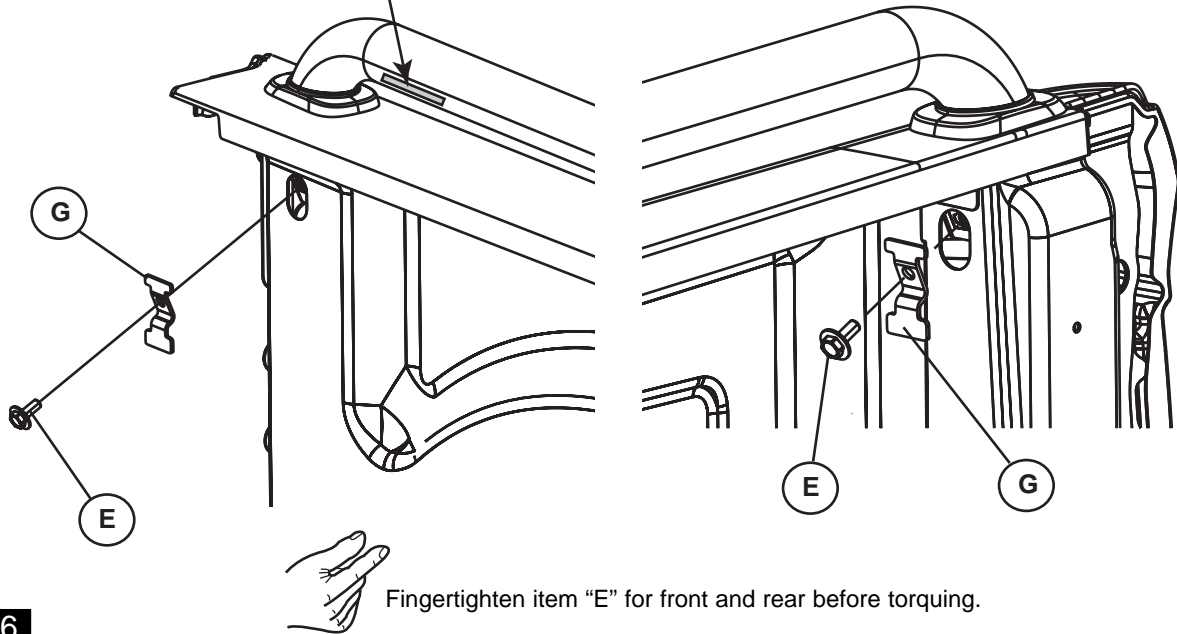

Fingertighten item "E" for front and rear before torquing.

6



20 +7/-0 (N.m)  
15 +5/-0 ft-lb

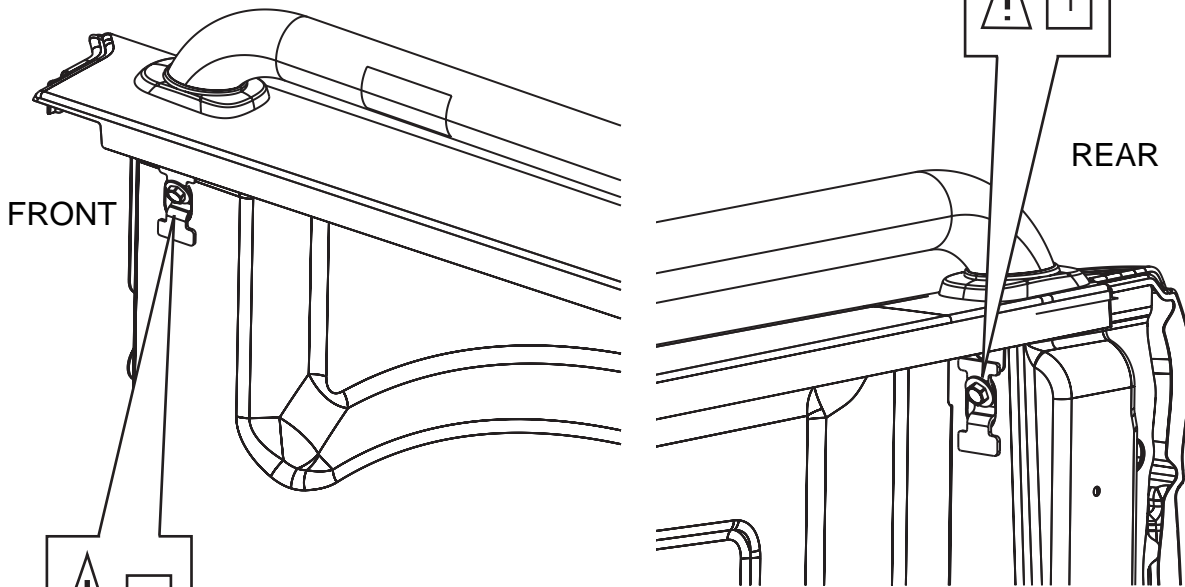

**! Torque sequence is critical. Torque rear attachment (!1) first, followed by the front attachment (!2).**

7